

Total No. of Questions : 4]

SEAT No. :

PC-438

[Total No. of Pages : 3

[6359]-559

**S.E. (Mech./Sandwich) (Automobile & Mechanical Engg.)
(Automation & Robotics Engg.) (Insem)**

SOLID MECHANICS

(2019 Pattern) (Semester - III) (202041)

Time : 1 Hour]

[Max. Marks : 30

Instructions to the candidates :

- 1) *Answer Q1 or Q2, Q3 or Q4.*
- 2) *Neat diagrams must be drawn wherever necessary.*
- 3) *Figures to the right side indicate full marks.*
- 4) *Assume Suitable data wherever necessary.*

Q1) a) A steel block 360mm × 80mm × 160mm is subjected to the following forces **[8]**

- i) A tensile force of 1280KN on the 160mm × 80mm faces (take as a X-direction)
- ii) A tensile force 3456 KN the 360mm × 80mm faces (take as a Y-direction) and
- iii) A compressive force of 5184KN on the 160mm × 360mm faces (take as a Z-direction)

Find the changes in the dimensions of the block and also the change in volume. Take $E = 2 \times 10^5 \text{ N/mm}^2$ and $1/m = 0.25$

- b) In a tensile test on steel tube of external diameter 18 mm and internal diameter 12 mm, an axial pull of 2 kN produces stretch of 6.72×10^{-3} mm in a length of 100 mm and lateral contraction of 3.62×10^{-4} mm in an outer diameter. Calculate the values of three Moduli and Poisson's ratio of material. **[7]**

OR

P.T.O.

- Q2) a) Determine the temperature change that will cause a compressive stress of 36 MPa in the composite bar as shown in fig. 2(a). Take $E_{st} = 210 \times 10^3 \text{ N/mm}^2$ and $E_{AL} = 0.7 \times 10^5 \text{ N/mm}^2$, $\alpha_s = 1.2 \times 10^{-5}$ and $\alpha_a = 2.30 \times 10^{-5}$ per $^\circ\text{C}$. [7]

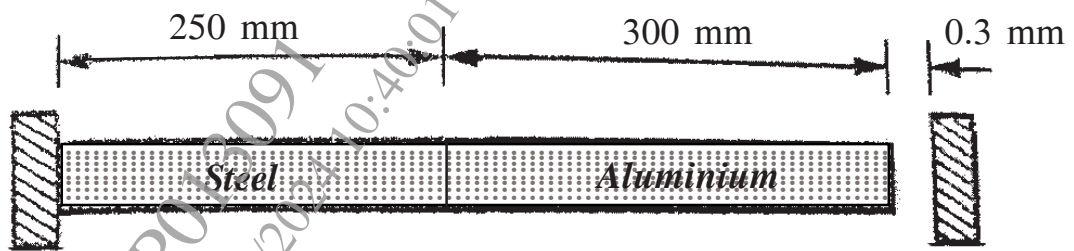

Fig.2(a)

- b) A rigid rod ABCD is supported by a hinge at A and two wires at B and C as shown in figure 2.(b). Determine the stresses and elongation of the two wires, Take $E_s=200 \text{ GPa}$ and $E_c=100 \text{ GPa}$ [8]

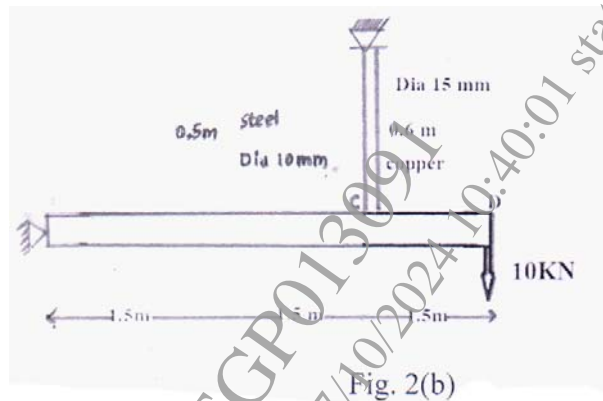

Fig. 2(b)

- Q3) a) Draw SFD & BMD of the beam shown in figure 3.(a), Also locate the point of contra-flexure from left end. [8]

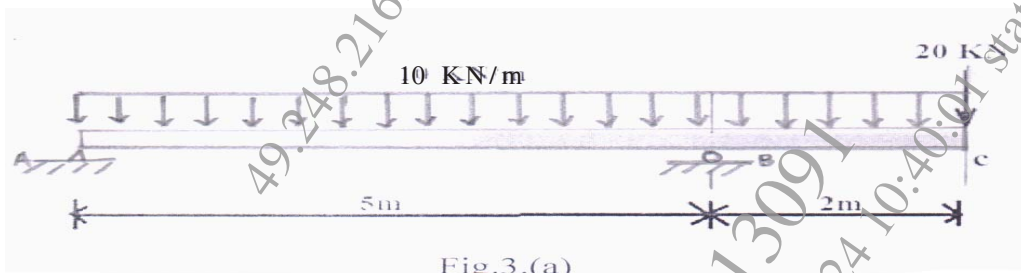

Fig.3.(a)

- b) Draw SFD & BMD of the beam shown in figure 3.(b), Also locate the point of contra-flexure from left end. [7]

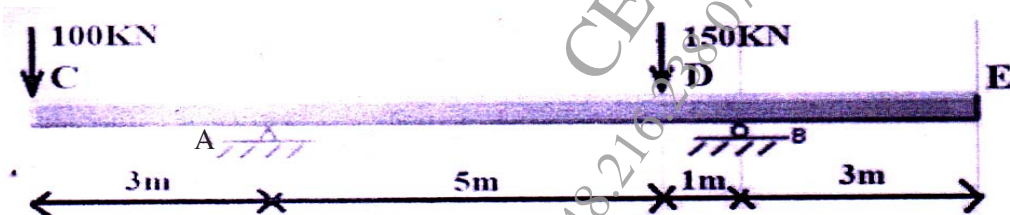

Fig.3.(b)

OR

- Q4) a) A beam AB 10 m is subjected to couples as shown in fig.4(a) Draw SFD and BMD and determine position of point of contra-flexure if any. [7]

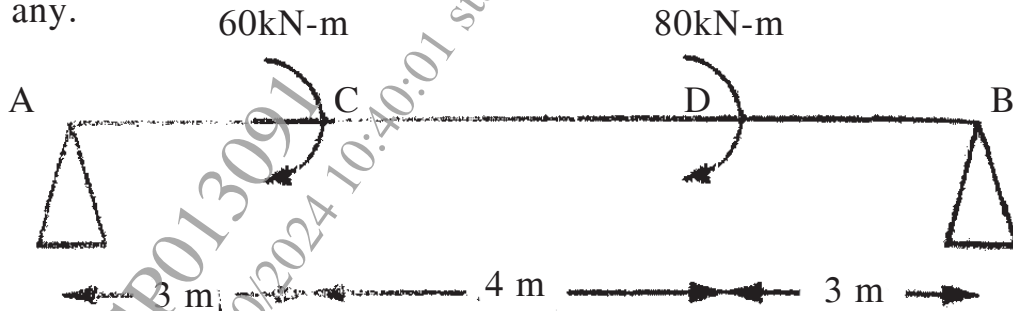

Fig. 4(a)

- b) Draw SFD and BMD for a beam shown in fig. 4(b). Determine zero shear force point from left support. [8]

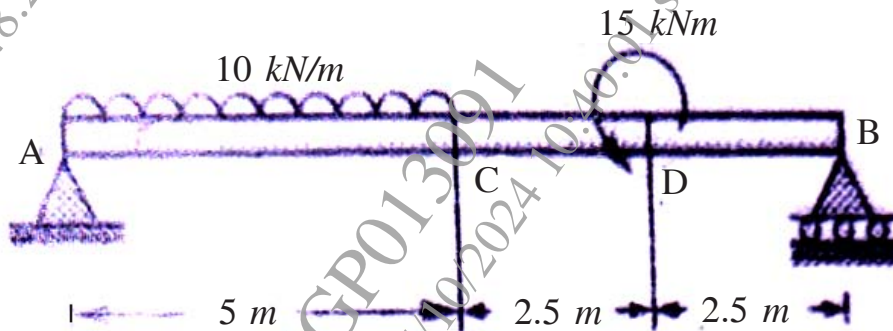

Fig. 4(b)
